

Installation and Calibration Instructions for the "MARINER" Model CH-1  
Close Hauled Indicator

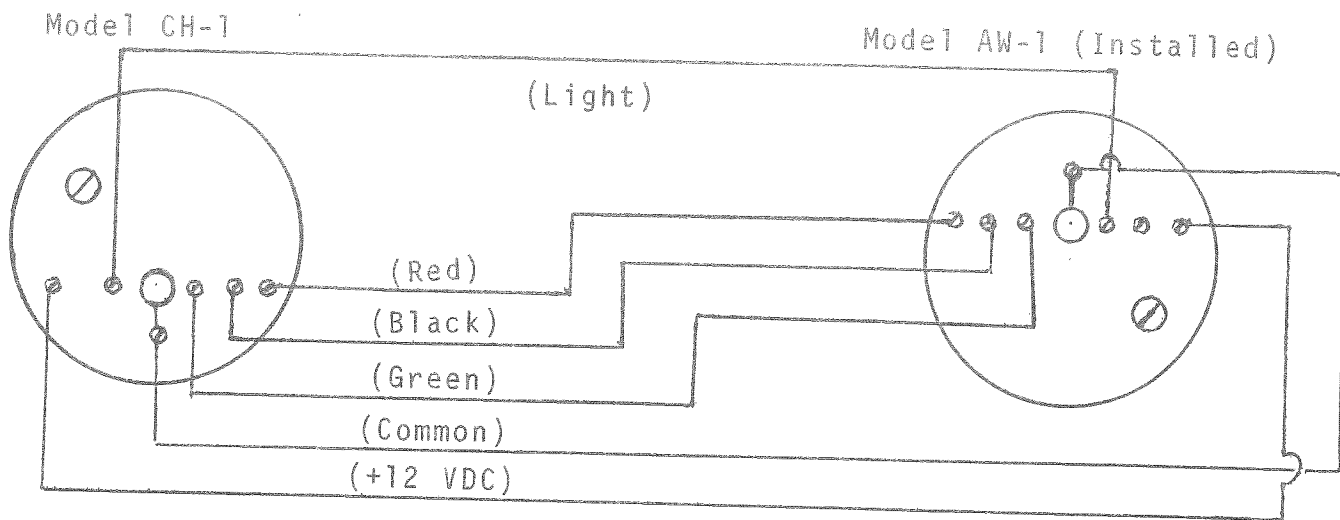

Follow the mounting instructions as provided for all displays. Proceed as follows:

- Step 1. Connect three wires between the Wind Vane terminals on the back plates of the Model AW-1 and the CH-1. Connect one wire between the terminals marked RED on each display, one wire between the terminals marked BLK and one wire between the terminals marked GRN.
2. Connect two additional wires. One to the terminals on each display marked COMMON and one to the terminals on each display marked Plus 12 V.
3. If you wish to light the CH-1 display and have power connected to the AW-1 Lighting circuit, run one additional wire to the terminal on each display marked LIGHT.

**CALIBRATION:** The Model CH-1 Close Hauled Indicator expands the 10 Degree to 50 Degree (Port or Starboard) range of the Model AW-1 Apparent Wind Indicator. The following procedure must be adhered to for the sake of accuracy.

- Step 1. After the Model AW-1 has been calibrated, turn the Wind Vane so that the Model AW-1 is reading 50 Degrees (Port or Starboard).
2. Remove the plastic plug from the hole marked CAL on the back plate of the CH-1.
3. Turn the calibration adjustment until the CH-1 indicates the same Degrees as the AW-1. Turning the adjustment Clockwise will increase the indicated Degrees as turning Counter-clockwise will decrease the reading. A small screw driver will serve this purpose.
4. Reinstall the plastic plug in the CAL hole and mount the display.