

SR MARINER

AWS-4

APPARENT WIND - WIND SPEED METER

Installation Instructions

Congratulations in choosing a high performance marine instrument and welcome to the growing family of SR Mariner product owners. Since our establishment in 1973, we have engineered our products to give you quality at a reasonable price.

To familiarize yourself with all the features and installation procedures please read the following instructions carefully.

If you still have any questions or comments please call your nearest dealer or call us at (716)693-5977 or write:

SR Instruments
600 Young Street
Tonawanda, NY 14150
Attn: Service Department

It is recommended that you temporarily hook up your SR MARINER equipment before installation so that you become familiar with its connections and system performance. **DO NOT CUT ANY CABLES**, but connect according to wiring diagram (fig.2). Spin the wind cups and turn the wind vane to test the system. If all functions perform satisfactorily, proceed with installation. If the system fails to perform, check all connections. If system still fails to perform check with your dealer for advice and or replacement if needed.

NOTES:

1. The wind speed display reads accurately to 75 knots.
2. If it necessary to have the unit face AFT the wind vane must be realigned. (First turn the vane so it points dead astern, then remove the vane by loosening the two allen set screws. Turn the potentiometer shaft until the display reads 180 degrees. Carefully install the vane pointing dead astern and tighten the screws. Seal the setscrews with loctite or equivalent.

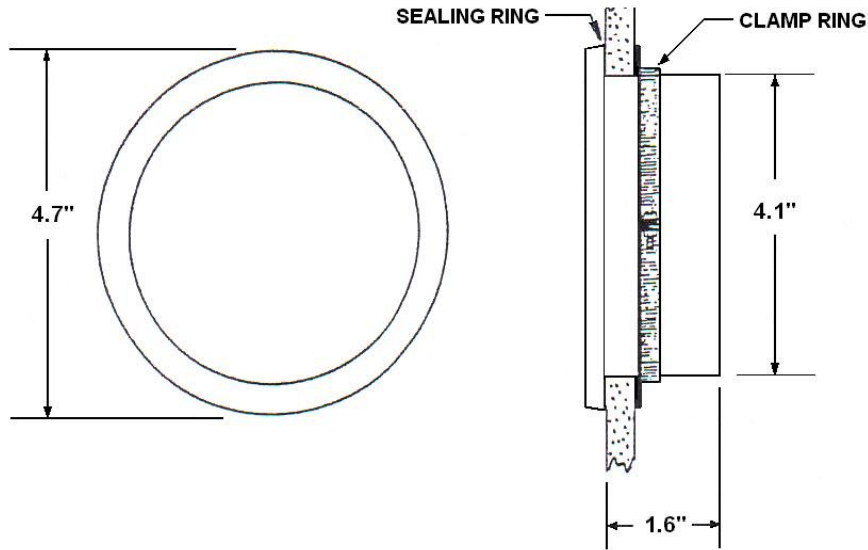

(Figure 1)

INSTALLING THE DISPLAY

1. Cut a 4-1/16" (max 4-1/8") diameter hole in the bulkhead or instrument panel where the display unit is to be mounted (fig.1).
2. Be sure to remove all burrs and clean the face of the bulkhead or panel with detergent to remove all traces of dirt, oils, fingerprints, etc...
3. Each display unit is furnished with an adhesive backed sealing ring to hold the unit fast in place and creates a watertight seal. Please note that it is not recommended that the paper backing be removed until the system is tested and finally calibrated. When ready for final mounting simply remove the paper backing, position unit correctly and firmly press into place.
4. Install the RETAINING RING as shown and tighten with a blade type screwdriver.

INSTALLING THE MAST UNIT

1. Mount the mast unit (CM) to the top of the mast facing FORWARD, using four screws.
2. Take the connector of the 65 foot cable and connect to the mast unit. Run the free end of the cable down or through the mast, exiting above or below the deck as conditions permit. Cut the cable to length.
3. Splice the 2 foot cable to the free end of the 65 foot cable. It is preferred to solder these connections and insulate with heat shrinkable tubing, but if this is not convenient, use the crimp connectors provided.
4. Connect the 20 foot cable and run the free end to the display. Cut to length and attach terminals to the wires.

BACK OF DISPLAY

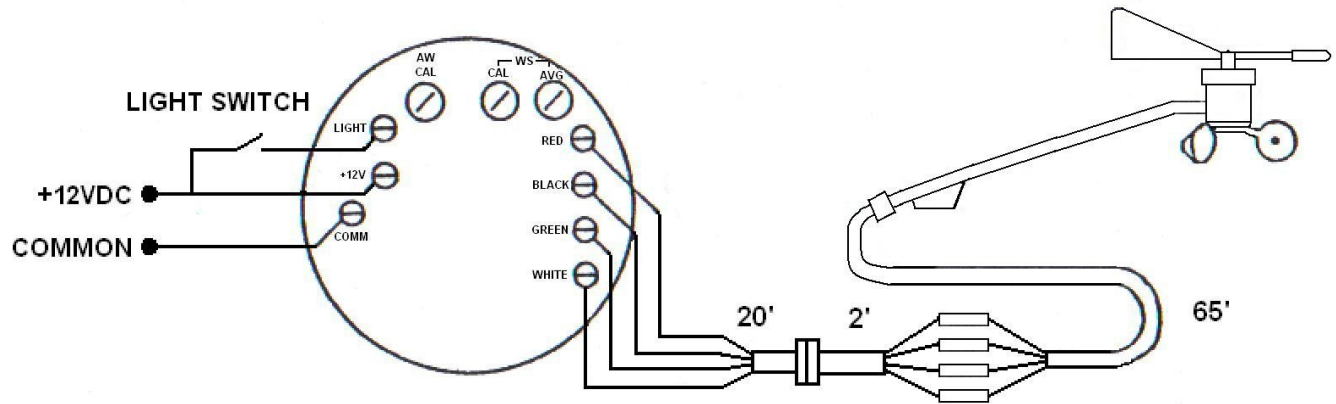

(Figure 2)

WIRING AND CALIBRATION

1. Connect the cable wires to the display as shown in figure 2.
2. If you choose to connect night lighting, simply connect your 12 volt D.C. wire as indicated above and install a SPST switch on the positive (+) line to complete the circuit and activate the lights.
3. Your units are factory calibrated and should not require any adjustments, however, if a condition exists to which you find it necessary to recalibrate, simply locate the calibration potentiometer that is marked for your needs.
4. Evaluate proper reading and adjust the calibration potentiometer accordingly.

POWER CONSUMPTION

LIGHTS	AMPS
OFF	.010A
ON	.090A

TROUBLESHOOTING

WIND DIRECTION NOT WORKING – It is easier to test the mast unit for fault. Measure the wires with an ohm meter to the following values. *(Please note that measurements should be taken after disconnecting wires from back of display. Also, if you turn the vane slowly, the values will STEADILY change. Only near 0 degrees is it supposed to be erratic).*

<u>WINDVANE POINTED</u>	<u>RESISTANCE ACROSS GR – BL</u>	<u>RESISTANCE ACROSS RED - BL</u>
10 STRBRD	0 OHMS	5K OHMS
90 STRBRD	1.3K OHMS	3.8K OHMS
180 DEGREES	2.5K OHMS	2.5K OHMS
90 PORT	3.8K OHMS	1.3K OHMS
10 PORT	5K OHMS	0 OHMS

The pins on the cable connectors are labeled 1-4 and the corresponding colors are RED, BLACK GREEN and WHITE:

WIND SPEED IS READING LOW- There are several possibilities for a low reading:

- (1) The generator may need lubrication. This is more apparent if you hear a vibration coming down the mast. Please follow the lubrication procedure further in the manual. *(Please note that if you find your anemometer cups breaking frequently, please check the generator).*
- (2) The display may need to be recalibrated. If you know what the wind speed is, then adjust the calibration potentiometer to that reading. If the wind speed is not known, then please use the following values to guide you for the proper wind speed reading:

Measure the GREEN and WHITE wires with a voltmeter on the AC scale using the following scale:

05 KNOTS = .30 VOLTS AC	20 KNOTS = 1.20 VOLTS AC
10 KNOTS = .60 VOLTS AC	25 KNOTS = 1.50 VOLTS AC
15 KNOTS = .90 VOLTS AC	30 KNOTS = 1.80 VOLTS AC

DIGITAL DISPLAY IS BLANK- The IC chip that drives the display needs replacing. Please send the display to the address on the front of the manual for repair.

ACCESSORIES

FRWV	WIND VANE
EV5K6637S	5K POT FOR MAST UNIT
FRAC	ANEMOMETER CUPS AND HARDWARE
FRAG	ANEMOMETER GENERATOR
FRICW-1	INSTRUMENT COVER
FRCLP RNG	CLAMP RING
FRMC-1	METER CASE FOR (YOUR MODEL NUMBER)
FRSEAL RING	GASKET FOR INSTRUMENT GAUGE

PROCEDURE FOR LUBRICATING ANEMOMETER GENERATOR

IMPORTANT: IT IS RECOMMENDED THAT THIS PROCEDURE BE DONE ON A FLAT CLEAN SURFACE. ALSO, BEFORE STARTING THE PROCEDURE, TAPE THE WEIGHTED END OF THE WINDVANE TO THE MAST PIPE TO ENSURE CORRECT VANE ORIENTATION AND CALIBRATION.

1. Remove cap plug, hex nut, and lock washer at the center of the three cup assembly.
2. Remove cup assembly from the threaded shaft by lightly prying apart.
3. Remove the 2 OUTER screws in the plastic cap located at the 3 and 9 o'clock positions.
4. Generator is now free to separate from housing.
5. Lubricate shaft above and below the magnet with a TEFLON base lubricant.
6. Reset the generator into housing, reversing step 4.
7. Replace the 2 outer screws in the cap that were removed in step 3.
8. Lubricate base of the threaded shaft where it meets the plastic cap.
9. Rotate shaft by hand to make sure it spins freely.
10. Reset cup assembly onto shaft while making sure they are seated properly.
11. Replace lock washer, hex nut, and cap from step 1.
12. Check operation of mast unit.

MASTUNIT ASSEMBLY

EXPLODED VIEW

